



F&J SPECIALTY PRODUCTS, INC.

The Nucleus of Quality Air Monitoring Programs

Tel: (352) 680-1177 • (352) 680-1178 / Fax: (352) 680-1454

Email: fandj@fjspecialty.com Internet: www.fjspecialty.com

GLOBAL MEGA HIGH VOLUME AIR SAMPLING SYSTEM F&J MODEL GAS-MHV300

NOTABLE FEATURES:

- Precision machined DP flow sensor
- State-of-the-Art electronics
- Vacuum fluorescent display; 4 lines×24 characters
- Flow rate and Volume measurements corrected to operator selectable Reference Temperature and Pressure
- Automatic flow control
- Operator selectable units of measurement
- Dual RS-232 communication ports
- Flow rate accuracy: ±3.0% Full Scale
- Auto zero calibration feature of flow sensor
- Continuous or periodic sampling mode
- Multiple operator selectable data storage rates
- Display of Multiple on-board calculations
- Powerful 1800 Watt motor
- 100-120VAC; 50/60Hz, single phase
- Clam Shell sample inlet with 46cm x 57cm filter media



GENERAL DESCRIPTION:

The GAS-MHV300 Series Air Sampling Systems are designed for remote unattended continuous air sampling applications. The GAS-MHV300 Series Air Samplers feature a brushless motor with electronic motor speed control that maintains a user selectable flow rate. The flow rate range attainable through the filter media is dependent upon the air porosity of the filter media. Flow rates as high as 176 CFM (300 m³/hr) or more are attainable with certain glass fiber filter media (depending on the air flow resistance of the filter media). The GAS-MHV300 Series design accommodates rapid field service and component replacement. The clam shell dual hemisphere inlet supports 46cm x 57cm filter media.

For durability and weather resistance, the system is housed in a freestanding powder coat painted aluminum enclosure. The sample air is drawn in under upper hemisphere in an omnidirectional geometry and is exhausted near the bottom of the enclosure. The locking swing door on the enclosure provides convenient access for servicing the equipment inside. A lockable latch of the top cabinet restricts unauthorized tampering of components within the enclosure. The clam shell sample inlet also has a locking mechanism.

The electronic flow control measurement sub-system of the GAS-MHV300 Series provides an operator selectable reference standard corrected flow measurement and a constant flow of air through the filter medium. The air velocity is measured by a precision-machined DP sensor. The controller can be readily set to any sampling flow rate between 50 and 200 CFM (85-340 m³/hr). The flow rate obtainable depends on the filter paper air resistance and dimensions. The bright VFD readout displays multiple air sampling information including current flow rate, average flow rate, current temperature and totalized volume. The filter holder can be custom designed to accommodate many large filter size and types. The GAS-MHV300 standard model utilizes a 46 cm x 57cm filter. Software is available to download air-sampling data via an RS-232 port. The software provides various management reports, file archiving and setup via a PC device.

GAS-MHV300 (100 – 120VAC)

Performance:

Basic components of the system are modular and independently serviceable. Sample flow rate can be set between 50 and 200 CFM (85 and 340 m³/hr). The standard filter holder has the dimensions 46cm x 57cm.

Technology: Microprocessor controlled state of the art electronics

Operating Temperature Range: 0°F to 122°F (-18°C to 50°C)

Typical Flow Rate Range: 50 – 200 CFM (85 to 340 m³/hr)
(Depending on filter paper dimensions and filter media air resistance)

Motor: Brushless: 2.4 H.P. (1800 Watt) motor with electronic motor speed control

Power: 100-120VAC; 50/60Hz; 30 amperes; single phase.

Housing: Powder coat painted aluminum Locking hinged cover
Removable hinged cover Locking swing door with key

Dimensions: 86”H × 44”W × 44”D (218cm H × 160cm W × 160cm D)

Weight: Approximately 175 lbs. (79,3 kg)

Shipping Weight: Approximately 200 lbs. (91 kg); Sample inlet and enclosure are shipped in separate boxes

Installation Category: Pollution Degree 3

Enclosure Rating: IPX3

Sample Inlet: Glass Reinforced Plastic

Automatic Flow Control:

The system microprocessor monitors flow rate relative to the operator selectable preset Reference T and P corrected flow rate established during the setup procedure and electronically adjusts the electronic motor speed adjustment, if necessary, to maintain the flow within $\pm 3.0\%$ of setting. The microprocessor computes the Reference flow rate by correcting the measured values of temperature and pressure to the reference values.

On-Board Measurement, Calculations and Other System Features

Measurements:

- Temperature of air flow through system
- Inlet pressure to the flow sensor
- Differential Pressure of the flow sensor
- Ambient pressure
- Pressure drop across the filter

Calculations/Determinations:

- Totalized volume, Reference T and P*
- Current flow rate, Reference T and P*
- Minimum and maximum temperature
- Minimum and maximum inlet pressure
- Elapsed time
- Ambient flow rate and volume
- * Operator selectable REF T and P

Other System Features:

- Display of data in English or metric units by selection
- Automatic shut off of system on totalized volume or elapsed time
- Real time clock with battery backup
- Various data storage options
- Dual password protection
Operator password
System Administrator password
- Dual RS-232 communication ports
- Periodic sampling scenario based on periods within a week selectable by the user
- Utilization of 46cm x 57cm rectangular filters
- Vacuum Fluorescent Display; 4 lines ×24 characters

Data Acquisition Software:

- Optional data communications software to download data from instrument to PC after completion of sampling activity

KEY MEASUREMENT IN PROGRESS INFORMATION

Elapsed Time and Flow Values

Elapsed time: 4,00:08
Current flow: 40.12 SCFM
Ambient flow: 40.24 CFM
Initial flow: 40.00 SCFM*

*Appears after 6th minute of operation

Average Flow Values and Volumes

Avg. std. flow: 39.12 SCFM
Avg. amb. flow: 40.24 CFM
Std. volume: 1.235E02 SCF
Amb. volume: 1.453E02 CF

Temperature and Pressure Values

Temperature: 23.3 C
Diff. press: 0.012 InHg
Inlet press: 29.87 InHg
Amb. press: 29.91 InHg

Flow, T and Ambient Pressure Ranges

Std. f: 39.02—41.19 SCFM
Amb. f: 40.14—40.33 CFM
Temp: 23.1—26.4 C
Amb. p: 29.81—29.99 InHg

DP Range, Gas and Ref. Values

DiffP: 0.012- 0.045 InHg
Initial flow: 40.00 SCFM
Ref. temp.: 21.1 C
Ref. press.: 29.92 InHg

Start time, End Mode, Current Time and Operating Mode Info

Start at: 29MAY2011 08:16
Stop at: 11JUN2011 08:16
Time: Wed 01JUN2011 08:20
Op: 5min per: 010011011101

POST MEASUREMENT INFORMATION

Start time, End Mode, Elapsed Time and Operating Mode Info

Start at: 29MAY2011 08:16
Stop at: 11JUN2011 08:16
Elapsed time: 0,12:11
Op: 5min per: 010011011101

Average Flow Values and Volume

Avg. std. flow: 39.12 SCFM
Avg. amb. flow: 40.24 CFM
Std. volume: 1.235E02 SCF
Amb. volume: 1.453E02 CF

Ref. and Amb. Flow, T and Amb. Pressure Ranges

Std. f: 39.02—41.19 SCFM
Amb. f: 39.14—41.33 CFM
Temp: 23.1—26.4 C
Amb. p: 29.81—29.99 InHg

DP Range, Initial Flow and Ref Values

DiffP: 0.012- 0.045 InHg
Initial flow: 40.00 SCFM
Ref. temp.: 21.1 C
Ref. press.: 29.92 InHg

Set up Flow and % Availability

Setup flow: 1 40.00 SCFM
% availability: 98.9 %

Gas, Storage Freq. and Power Outages Info

Gas: Air
Storage freq.: 1 min
Power outages: 1
Duration: 0,00:12

Additional Power Outage Info

29MAY 08:14, L: 0,00:12

EXIT



Frontal View – Sample Inlet Closed



Frontal View – Sample Inlet Open



View of Open Sample Inlet

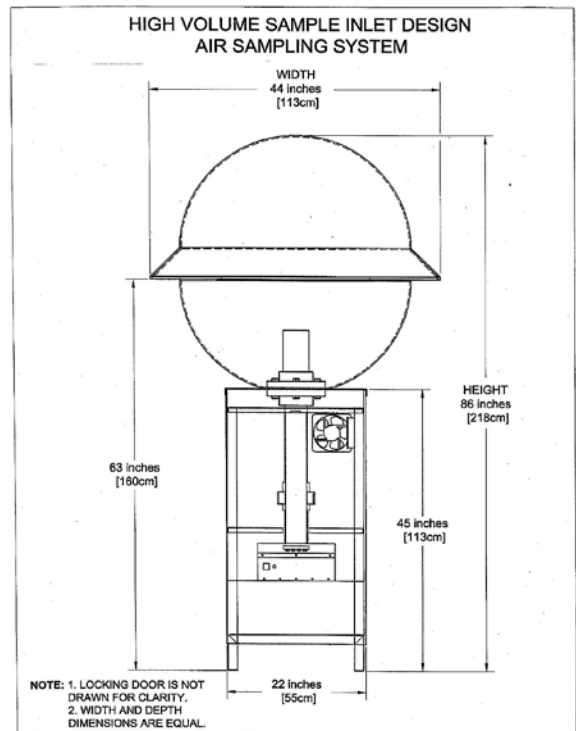

Dimensional Sketch